

HDT series - GRIPPER (Double force)

Operation specification and Ordering expression

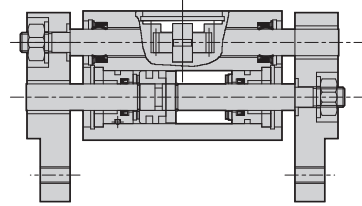

Internal structure

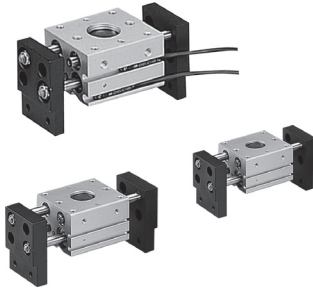

Specification

New

Item	Model	HDT-10	HDT-16	HDT-20	HDT-25	HDT-32	HDT-40
Bore size		10	16	20	25	32	40
Type of operation		Double acting					
Fluid		Air					
Pressure range	kgf/cm ² (kpa)	1.5 ~ 7 (150 ~ 700)					
Range of service temperature	°C	0 ~ 60					
Max. operation frequency	min	40	40	40	40	20	20
Lubrication		Lubrication free					
Gripping force	kgf [N]	1.4(14)	4.5(44)	7.4(73)	13.1(128)	23.2(228)	40(396)
Max. Length of gripping point (L)	mm	40	60	80	90	100	100
Lever open/close stroke	mm	20,40,60	30,60,80	40,80,100	50,100,120	70,120,160	100,160,200
Port size	mm	M5X0.8P				Rc 1/8	
Magnet device		With magnet					

Note : L : Length of point , 10、16、20、25 = 40mm , 32、40 = 80mm , M : Theoretical gripping Torque , P : Pressure=5 Kgf/cm²

How to order

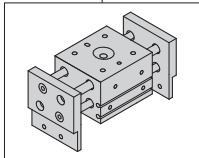
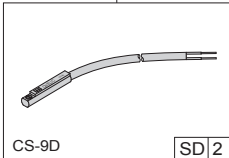
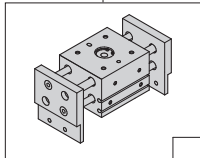
HDT	20	×	100	—	SD	2	—	
Model	Bore size		Stroke		Sensor switch			Claw type
	10 - Ø 10 mm 16 - Ø 16 mm 20 - Ø 20 mm 25 - Ø 25 mm 32 - Ø 32 mm 40 - Ø 40 mm		Ø10 - 20 , 40 , 60 mm Ø16 - 30 , 60 , 80 mm Ø20 - 40 , 80 , 100 mm Ø25 - 50 , 100 , 120 mm Ø32 - 70 , 120 , 160 mm Ø40 - 100 , 160 , 200 mm					

HDT : Gripper

None : Without sensor

[SD] : Sensor code(CS-9D)

[SB] : Sensor code(CS-9B)

[SH] : Sensor code(CS-9H)

[SDN] : Sensor code(CS-9DN)

[SDP] : Sensor code(CS-9DP)

[SG] : Sensor code(CS-8G)

[SGN] : Sensor code(CS-8GN)

[SGP] : Sensor code(CS-8GP)

※ CS-9H use for voltage

AC / DC 5 ~ 240V

[2] : Number of sensor

1 = 1 PCS

2 = 2 PCS

None : Standard

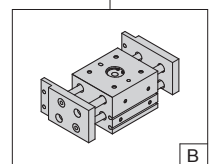

B : Side tapped mounting

HDS
Angular
Gripper

HDM
180°Angular
Gripper

HDP
Parallel
Gripper

HDK
Parallel
Gripper

HDF
Parallel
Gripper

HDX
Parallel
Gripper

HDL
Parallel
Gripper

HDM
Parallel
Gripper

HDL
Gripper

HDT
Gripper

HDR
Three
Finger
Gripper

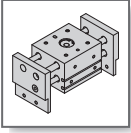

HDT series - GRIPPER (Double force)

Components and Material list



Internal structure

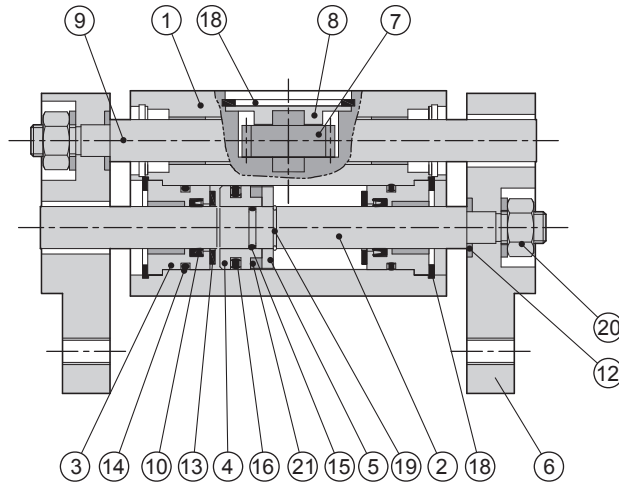

Components and Material list

No.	Item	Material	No.	Item	Material
01	Body	Aluminum alloy	12	Gasket	Iron
02	Piston rod	Middle carbon steel	13	Gasket	PU
03	Front cover	Aluminum alloy	14	Front cover O-Ring	NBR
04	Piston	Copper	15	Piston O-Ring	NBR
05	Magnet cover	Copper	16	Piston packing	NBR
06	Finger	Aluminum alloy	17	Gear cover snap ring	Spring steel
07	Gear rod	Middle carbon steel	18	Front cover snap ring	Spring steel
08	Gear cover	Iron	19	Rod snap ring	Spring steel
09	Guide rod	Stainless steel	20	Mounting nut	Bearing steel
10	Rod packing	NBR	21	Magnet	REM
11	Bearing	Teflon			

Packing and O-Ring

Bore size	Item		Piston packing	Rod packing	Front cover O-Ring	Piston O-Ring
	mm	Number	2	4	4	2
Ø10			DYP-10	DYR-6	Ø 8.0 X Ø1.0	Ø 4.0 X Ø1.0
Ø16			COP-16	DYR-8K	Ø 13.2 X Ø1.5	Ø 6.3 X Ø0.8
Ø20			COP-20	DYR-10SK	Ø 17.5 X Ø1.5	Ø 8.0 X Ø1.0
Ø25			COP-25	DYR-12	Ø 20.8 X Ø2.0	Ø 10 X Ø1.0
Ø32			COP-32	DYR-16	Ø 28.5 X Ø2.0	Ø13.5 X Ø1.5
Ø40			COP-40	EM-2025	Ø 36 X Ø2.0	Ø 12 X Ø1.5

New

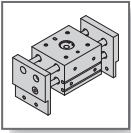

HDT series - GRIPPER (Double force)



Gripping force characteristic

► Gripping point

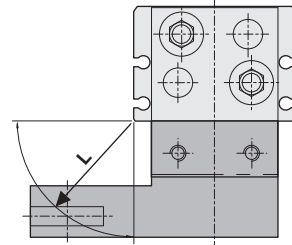
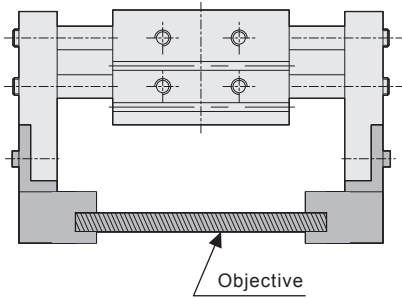

L : Gripping position mm

► Gripping force characteristic

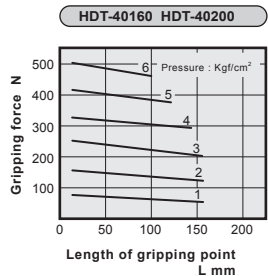
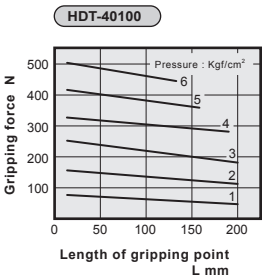
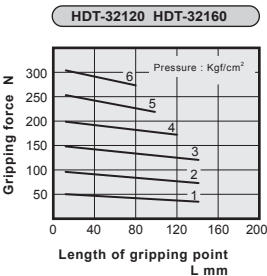
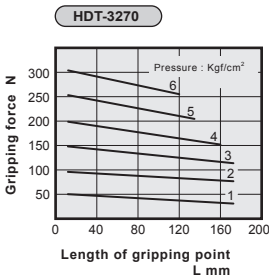
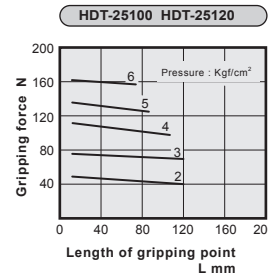
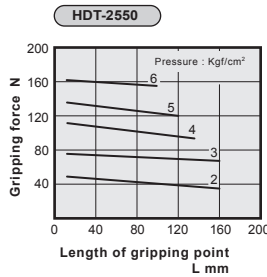
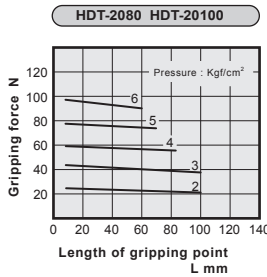
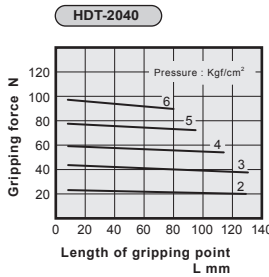
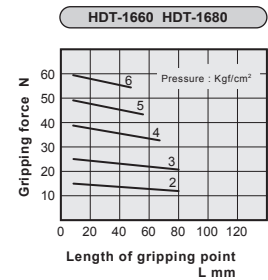
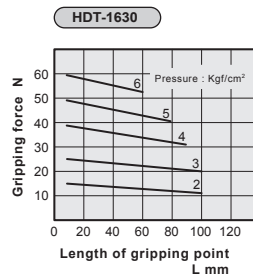
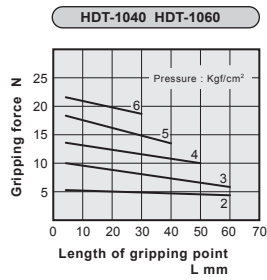
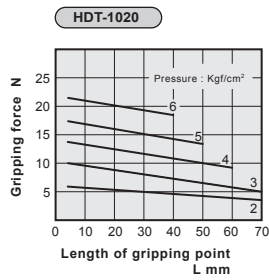

HDS
Angular
Gripper

HDM
180° Angular
Gripper

HDP
Parallel
Gripper

HDK
Parallel
Gripper

HDF
Parallel
Gripper

HDZ
Parallel
Gripper

HDZL
Parallel
Gripper

HDW
Parallel
Gripper

HDL
Gripper

HDT
Gripper

HDR
Three
Finger
Gripper

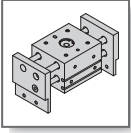

HDT series - GRIPPER (Double force)



Mounting type and Sensor switch installation

▶ Finger type (2 types)

▶ Standard type

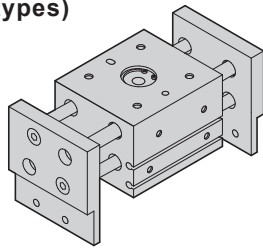

▶ Finger side gripper — [B]

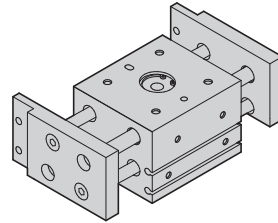

▶ Mounting type (2 types)

▶ Top side mounting type

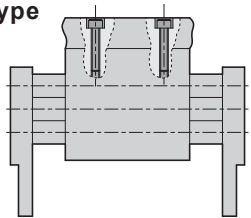

▶ Side mounting type

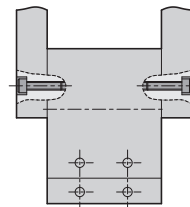

▶ Response differential and Operating range ▶ Sensor switch installation

Model	CS-9D(B)	
Bore size	Operating range F	Response differential R
10	5	1.1
16	5	1.1
20	8.5	1
25	10	1.8
32	10	2
40	10	1.8

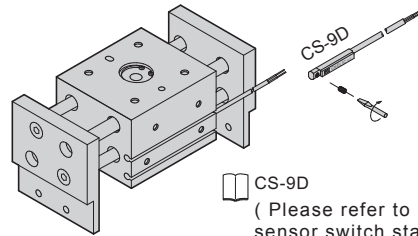

CS-9D

(Please refer to P.22-1.15 sensor switch standard)

▶ Model Selection Example



Work form
Diameter x Length
130 mm x 30 mm plate

Work length: From the dimensions of models that have an opening width of 130 mm or more

HDT-1660 · HDT-1680
HDT-2080 · HDT-2550

Work mass: 0.2 kg

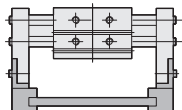

- According to the work piece shape and the coefficient of friction between the attachments and the work piece, select a model that can provide a gripping force of 10 to 20 times the work piece mass, or more.
- Further allowance should be provide when great acceleration or impact is expected during work piece transfer.
Ex. For seeing the gripping force to be at least 20 times the work piece mass :
Required gripping force = $0.2 \text{ kg} \times 20 \times 9.8 \text{ m/s}^2 \approx 40 \text{ N}$

Gripping point R=40mm

Operating pressure: 5 kgf/cm²

HDT-1660 / HDT-1680

Selecting HDT-1660
A gripping force of 45N is obtained from the intersection point of gripping point position R=40mm and a pressure 5kgf/cm²
The gripping force is 22.5 times greater than the workpiece mass, and therefore satisfies a gripping force setting value of 20 times or more.

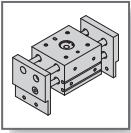

HDT series - GRIPPER (Double force)

External dimension



► HDT - 10

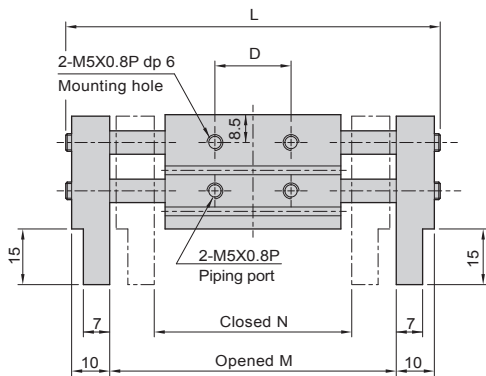
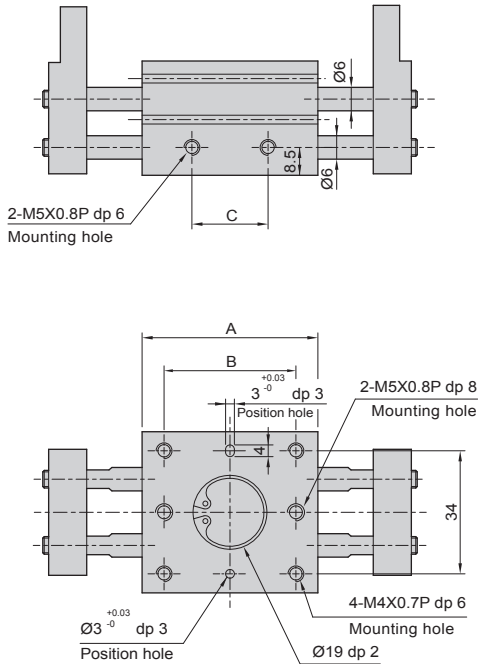

► HDT-10 □ B (Claw side clamp type)

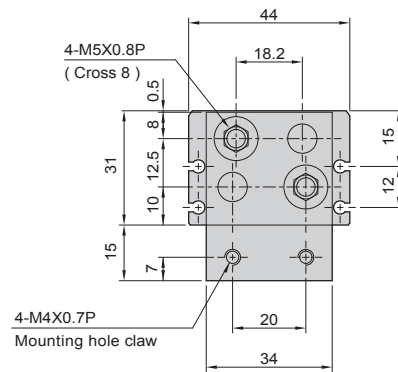
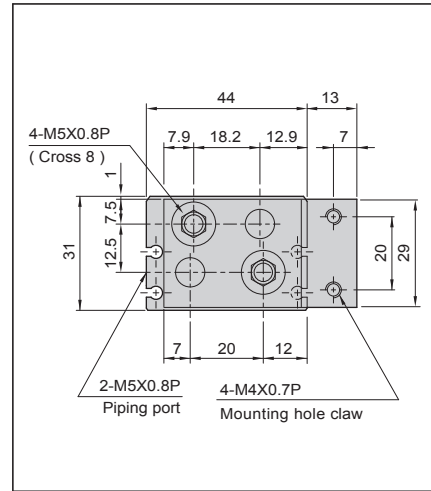

HDS
Angular
Gripper

HDM
180°Angular
Gripper

HDP
Parallel
Gripper

HDK
Parallel
Gripper

HDF
Parallel
Gripper

HDZ
Parallel
Gripper

HDZL
Parallel
Gripper

HDW
Parallel
Gripper

HDL
Gripper

HDT
Gripper

HDR
Three
Finger
Gripper

Model	A	B	C	D	L	M	N
HDT - 1020 □	52	36	30	30	100(80)	76	56
HDT - 1040 □	68	52	46	46	136(96)	112	72
HDT - 1060 □	86	70	64	64	174(114)	150	90

► Weight

Model	HDT-1020	HDT-1040	HDT-1060
Weight kg	0.29	0.35	0.44

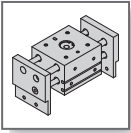

HDT series - GRIPPER (Double force)

External dimension



► HDT - 16

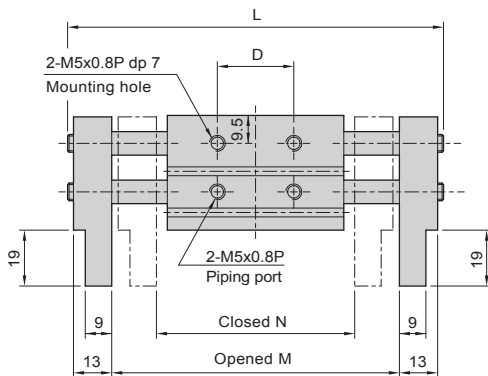
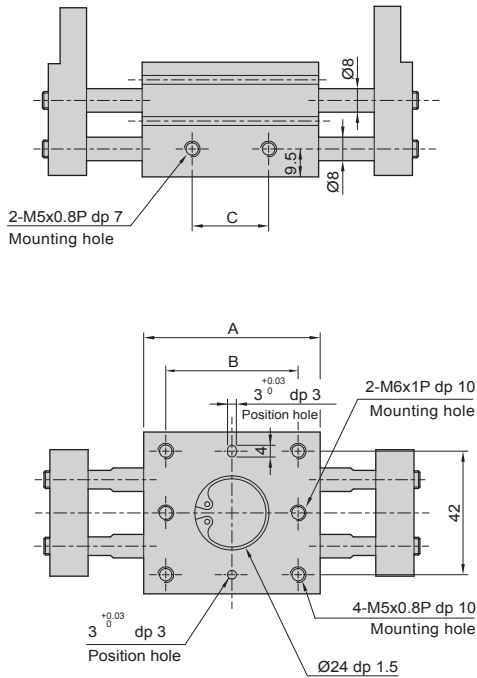

► HDT-16 □ B (Claw side clamp type)

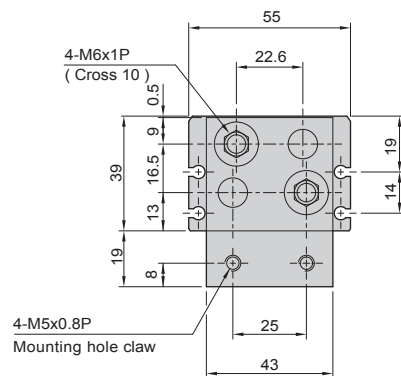
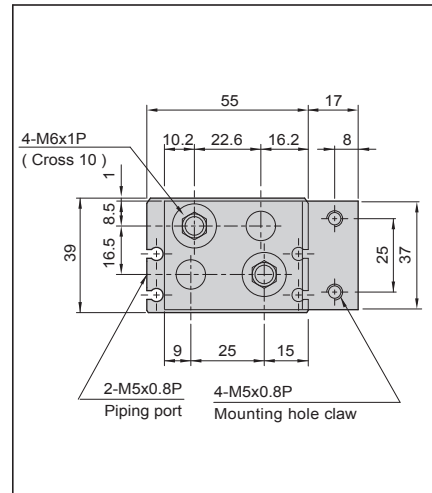

Model	A	B	C	D	L	M	N
HDT - 1630 □	60	45	26	26	128(98)	98	68
HDT - 1660 □	90	75	56	56	188(128)	158	98
HDT - 1680 □	110	95	76	76	228(148)	198	118

► Weight

Model	HDT-1630	HDT-1660	HDT-1680
Weight kg	0.57	0.79	0.94

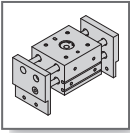

HDT series - GRIPPER (Double force)

External dimension



► HDT - 20

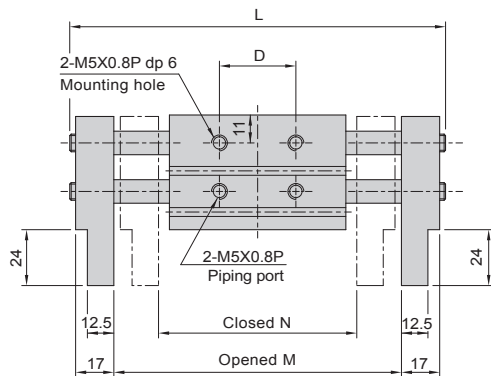
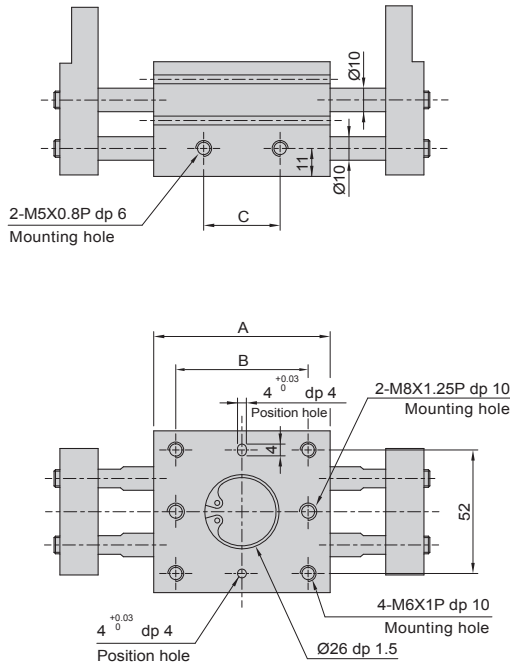

► HDT-20 □ B (Claw side clamp type)

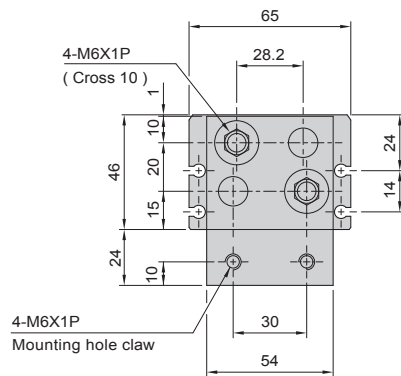
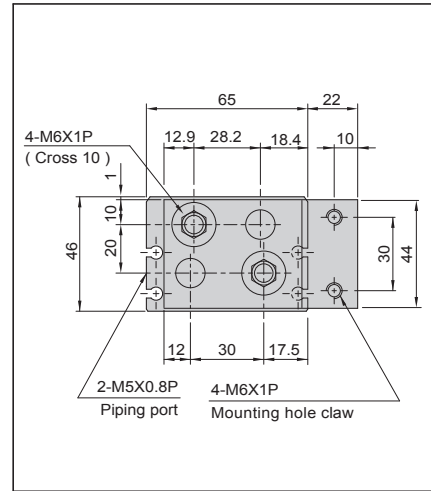

HDS
Angular
Gripper

HDM
180°Angular
Gripper

HDP
Parallel
Gripper

HDK
Parallel
Gripper

HDF
Parallel
Gripper

HDZ
Parallel
Gripper

HDZL
Parallel
Gripper

HDW
Parallel
Gripper

HDL
Gripper

HDT
Gripper

HDR
Three
Finger
Gripper

Model	A	B	C	D	L	M	N
HDT - 2040 □	71	58	40	40	157(117)	119	79
HDT - 2080 □	113	100	82	82	239(159)	201	121
HDT - 20100 □	133	120	102	102	279(179)	241	141

► Weight

Model	HDT-2040	HDT-2080	HDT-20100
Weight kg	1.0	1.45	1.7

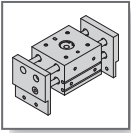

HDT series - GRIPPER (Double force)



External dimension

► HDT - 25

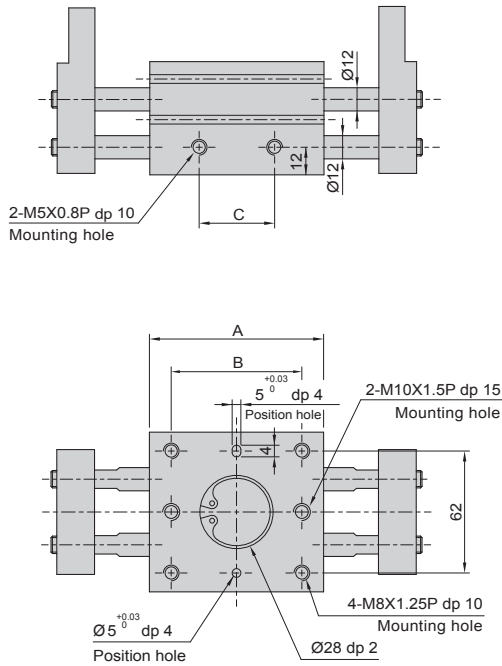

► HDT-25 □ B (Claw side clamp type)

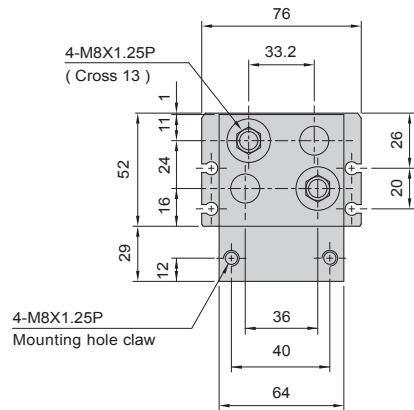
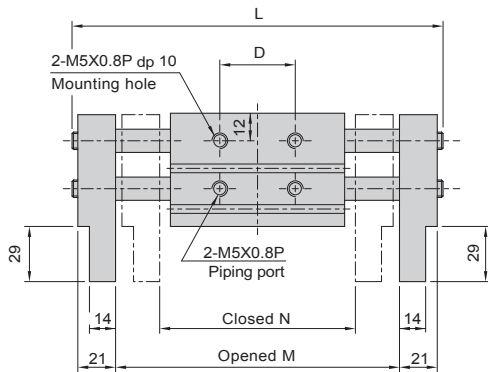
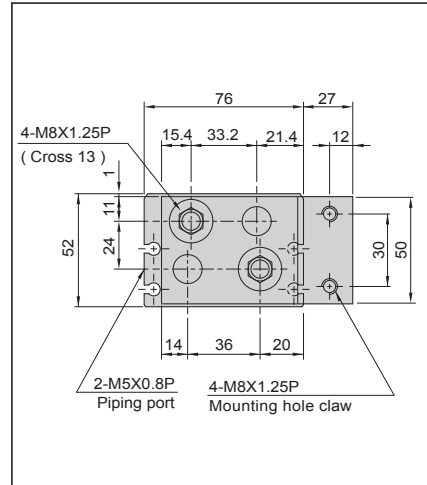

Model	A	B	C	D	L	M	N
HDT - 2550 □	88	70	50	50	192(142)	146	96
HDT - 25100 □	142	124	104	104	296(196)	250	150
HDT - 25120 □	160	142	122	122	334(214)	288	168

► Weight

Model	HDT- 2550	HDT-25100	HDT-25120
Weight kg	1.7	2.6	2.8

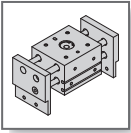

HDT series - GRIPPER (Double force)

External dimension



► HDT - 32

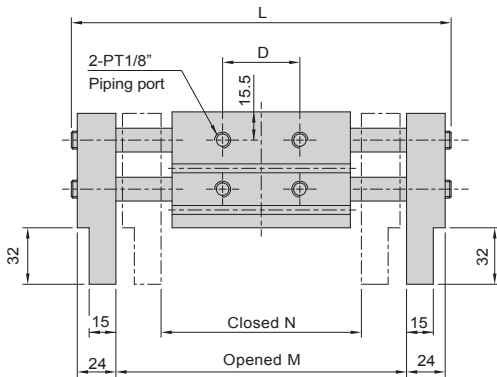
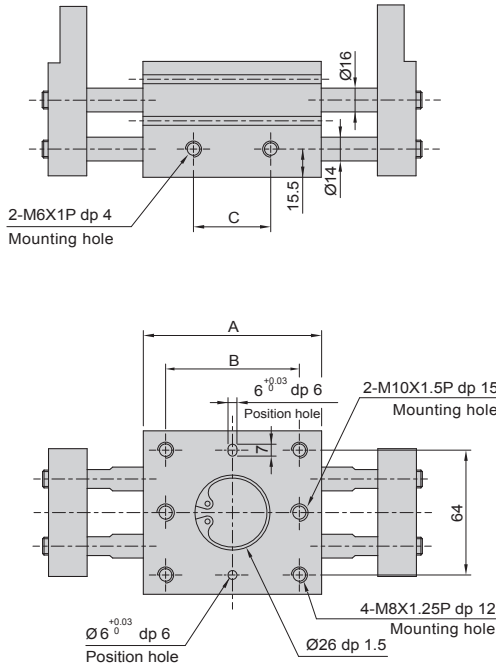

► HDT-32 □ B (Claw side clamp type)

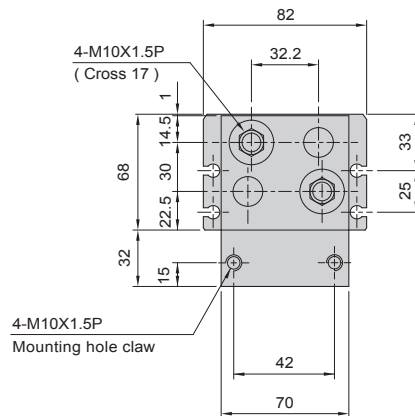
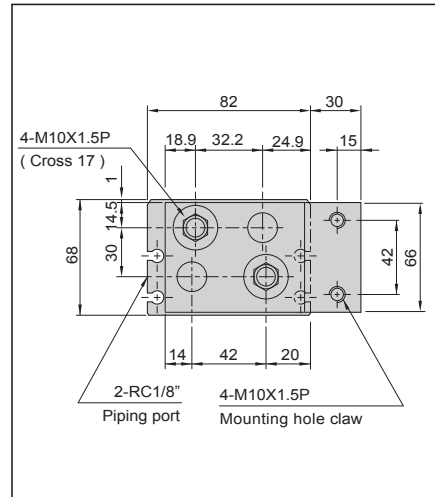

HDS
Angular
Gripper

HDM
180°Angular
Gripper

HDP
Parallel
Gripper

HDK
Parallel
Gripper

HDF
Parallel
Gripper

HDZ
Parallel
Gripper

HDZL
Parallel
Gripper

HDW
Parallel
Gripper

HDL
Gripper

HDT
Gripper

HDR
Three
Finger
Gripper

Model	A	B	C	D	L	M	N
HDT - 3270 □	110	86	69	69	240(170)	188	118
HDT - 32120 □	158	134	117	117	338(218)	286	166
HDT - 32160 □	202	178	161	161	422(262)	370	210

► Weight

Model	HDT- 3270	HDT-32120	HDT-32160
Weight kg	3	4.03	5.01

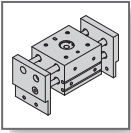

HDT series - GRIPPER (Double force)

External dimension



► HDT - 40

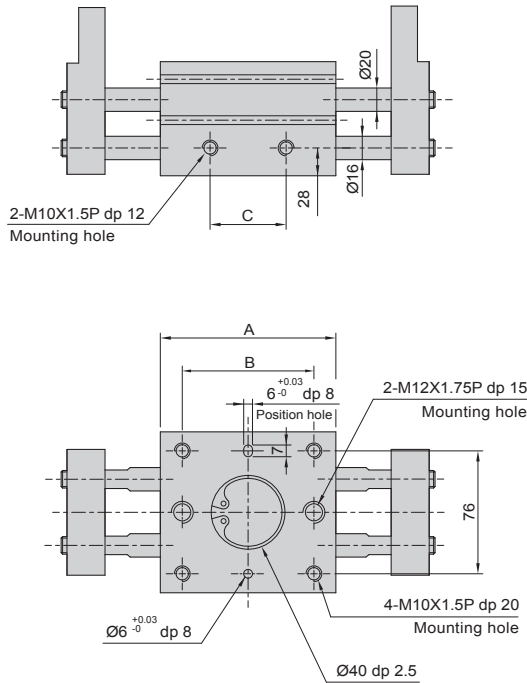

► HDT-40 □ B (Claw side clamp type)

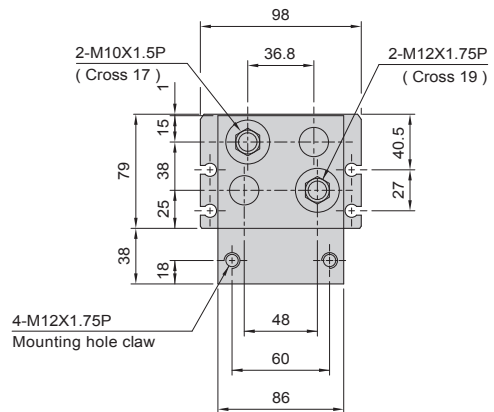
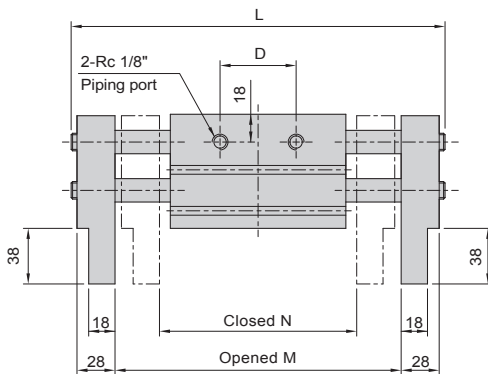
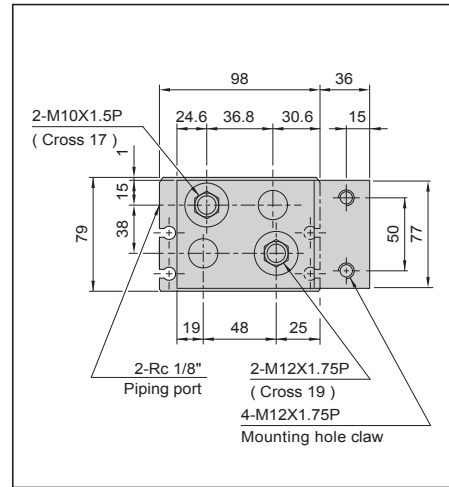

Model	A	B	C	D	L	M	N
HDT - 40100 □	148	116	80	80	256(324)	264	164
HDT - 40160 □	206	174	138	138	370(442)	382	222
HDT - 40200 □	246	214	178	178	450(522)	462	262

► Weight

Model	HDT-40100	HDT-40160	HDT-40200
Weight kg	5.3	6.9	8